

## Pallet Forks PGA-K with Security Chain

**Automatic-Centre-of-Gravity-Balance due to a spring-loaded slide** mounted on a maintenance free steel-polyamide-slide-bearing.

### Standard Specifications:

- ▶ Crane eye
- ▶ Adjustable height from 1,050–1,650 mm (41<sup>1</sup>/<sub>2</sub>– 1<sup>1</sup>/<sub>2</sub>").

- ▶ Adjustable fork distance from 340–1,000 mm (13<sup>1</sup>/<sub>2</sub>– 39<sup>1</sup>/<sub>2</sub>").
- ▶ Security chain with eyelet and chain box for securing the load against slipping off.
- ▶ Length of forks 980 mm

Type	Fork Dimension mm (in)	Working Load Limit WLL kg (lbs) at 500 mm (20" in)	Dead Weight kg (lbs)	Order-Number
PGA-15-K*	100 x 40 (4 x 1 <sup>1</sup> / <sub>2</sub> " )	1,500 (3,300)	95 (210)	5600.0006
PGA-20-K*	120 x 40 (4 <sup>3</sup> / <sub>4</sub> x 1 <sup>1</sup> / <sub>2</sub> " )	2,000 (4,400)	120 (265)	5600.0007
PGA-25-K	100 x 45 (4 x 1 <sup>3</sup> / <sub>4</sub> " )	2,500 (5,500)	160 (355)	5600.0008
PGA-30-K	125 x 45 (5 x 1 <sup>3</sup> / <sub>4</sub> " )	3,000 (6,600)	180 (395)	5600.0009

\* Additional fork lengths see page 9.2

Minimum loading weight is approx. 25 % of the load.

Stated minimum loading weight is necessary for the automatic gravity function to work.

Optional with standard flange plate mounted on the PGA-K for the direct assembly of the rotator or the Quick Change Device SWV.

### Accessories

Type	Order-Number
NH-PGE-15/20 Net Holder incl. Security Net SSN for PGE	4500.0021
NH-PGA-15/20 Net Holder incl. Security Net SSN for PGA	4500.0008

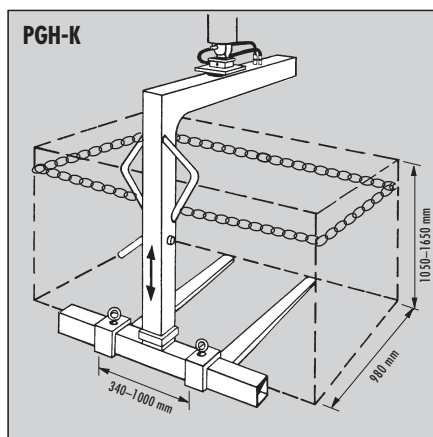

## Pallet Forks PGH-K with Security Chain

Comes with hydraulically operated centre-of-gravity-balance, enabling the forks to tilt forward and backwards in the full and empty position.

Also with rotator making it a purely one-man machine on even ground.

▶ Equipped as standard with security chain, thus approved as per rule EN 13155 for transport of individual loads (such as plastic coated, palletized loads).

▶ Approved for use with truck loading cranes for unloading packs of building material at construction sites at near-ground areas without application of security chain.

### Standard Specifications:

- ▶ Standard flange plate to mount the rotator or quick-change-device.
- ▶ Adjustable height from 1,050 – 1,650 mm (41 – 65").
- ▶ Adjustable fork width from 340 – 1,000 mm (13<sup>1</sup>/<sub>2</sub> – 39") (external).
- ▶ Forks have long taper for optimal engagement.
- ▶ Length of forks 980 mm (38<sup>1</sup>/<sub>2</sub>").

Type	Fork Dimension mm (in)	Working Load Limit WLL kg (lbs) at 500 mm (20" )	Dead Weight kg (lbs)	Order-Number
PGH-15-K	100 x 40 (4 x 1 <sup>1</sup> / <sub>2</sub> " )	1,500 (3,300)	120 (265)	5600.0010
PGH-20-K	120 x 40 (4 <sup>3</sup> / <sub>4</sub> x 1 <sup>1</sup> / <sub>2</sub> " )	2,000 (4,400)	125 (275)	5600.0011
PGH-25-K	100 x 45 (4 x 1 <sup>3</sup> / <sub>4</sub> " )	2,500 (5,500)	165 (365)	5600.0025
PGH-30-K	125 x 45 (4 <sup>3</sup> / <sub>4</sub> x 1 <sup>3</sup> / <sub>4</sub> " )	3,000 (6,600)	185 (410)	5600.0024

Surcharge for modified effective fork length available of request.

### Accessories for Pallet Forks

We recommend the Quick Change Device SWV (see page 15.7) for use with truck loading cranes with a hydraulic rotator.

See page 9.1 and 9.2, for pallet forks being used on tower cranes, with additional safety features.