



DV60
Dual View Trucks



The driver's cab concept allows the operator to turn the seat and console 180 degrees to determine the viewing and driving direction. The rotation can be conveniently performed from the driver's seat by simple unlocking the seat console and then turn it around.

Always on the safe side

With the Dual View, the operator always has full visibility ahead: when unloading, he looks in the direction of the skip, before continuing driving he turns the seat and has unrestricted view in the driving direction. More visibility also means more safety. The driver sees where he is driving and better recognize potential dangers. Even annoying and potentially dangerous maneuvering or reversing is eliminated with the DV60 Dual View completely.



High driving position:

The Dual View safely runs as a construction truck, but is significantly more suitable for off-road applications.



High working position:

Full load monitoring and precise dumping.

Hydrostatic drive

- The vehicle stops as soon as the operator takes his foot off the gas pedal
- Full focus on the job without frequent gear changes
- One central hydraulic motor that drives both axles via a cardan shaft
- Hydrostatic braking effect as soon as the foot is removed from the accelerator pedal
- Low-wear drive for low service and maintenance costs
- Controlled deceleration for regulated changeover, thus no abrupt changes of travel
- Accelerate from 0 to maximum speed of 20km/h without loss of traction

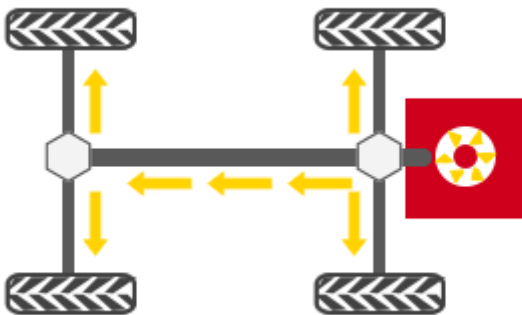

More ease of use thanks to the ergonomic rotary console.

Easy 180° rotation - time-consuming turning maneuvers are obsolete.

1. Joystick handle with direction change switch and dump operation, so one hand can always stay on the steering wheel.
2. Multifunction display for machine functions
3. Standard rear-view camera monitor, so you can always see the skip in any seating position.
4. Steering column with tilt adjustment simplifies safe entry and exit
5. Additional storage space
6. Ball bearing slewing ring for quick change of the seat position



Simply see more.

The DV60 Dual View stands out clearly from the requirements of the field of view standard ISO 5006: 2017.

Beyond the green marked area, the operator can see a height of 1.2 m from the cabin in the Dual View.

Beyond the dashed line, it is required to see a height of 1.2 m according to the ISO field of view standard.

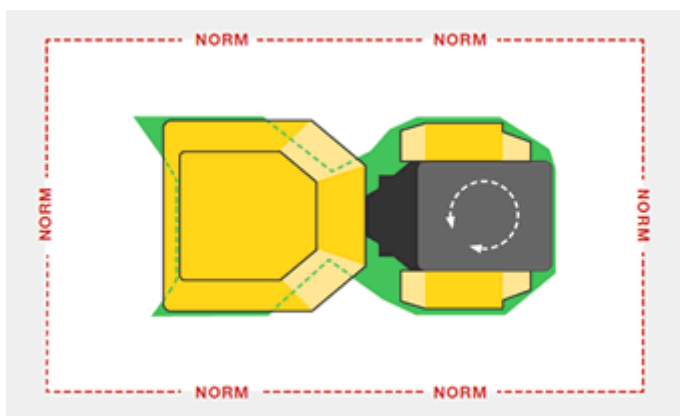

Comfort cabin

The DV60 Dual View provides plenty of head and legroom inside the cabin. It is equipped with heating as standard and air



conditioning is optionally available. The operator can work under ideal temperature conditions in summer as well as in the winter times. For extra safety, the cabin is always equipped with ROPS/FOPS Level II.



Driving direction



Skip direction

Entering the driver's cab

Safe and comfortable ascent to the driver's station. The steps are highlighted with color for better visibility.



**WACKER
NEUSON**
all it takes!





DV60 Technical specifications

	Front tip skip	Swivel tip skip
Operating data		
Payload kg	6,000	6,000
Skip capacity - stroke l	2,700	2,350
Skip capacity - heaped l	3,600	3,150
Skip capacity - water measure l	1,900	1,600
Engine / Motor		
Engine / Motor manufacturer	DEUTZ	DEUTZ
Engine / Motor type	4L	4L
Engine / Motor	water-cooled 4-cylinder turbo-diesel	water-cooled 4-cylinder turbo-diesel
Engine performance kW	55.4	55.4
Displacement cm ³	2,900	2,900
Engine RPM rpm	2200	2200
Emissions	level 3b / Tier IV final	level 3b / Tier IV final
Traction drive	4WD / hydrostatic	4WD / hydrostatic
Travel speed max. km/h	30	30
Articulation angle °	29	29
Pendulum angle °	11	11
Turning radius mm	6,100	5,980
Gradeability %	55	55
Tires	405/70-20	405/70-20
L x W x H mm	4,450 / 2,230 / 3,300	4,450 / 2,230 / 3,300
Steering pump	axial piston pump	axial piston pump
Flow rate l/min	123	123
Operating pressure bar	480	480
Duty pump	gear pump	gear pump
Flow rate l/min	70.2	70.2
Operating pressure bar	240	240
Tank capacity l	80	80
Sound level (LwA) dB(A)	101	101



DV60 Dimensions

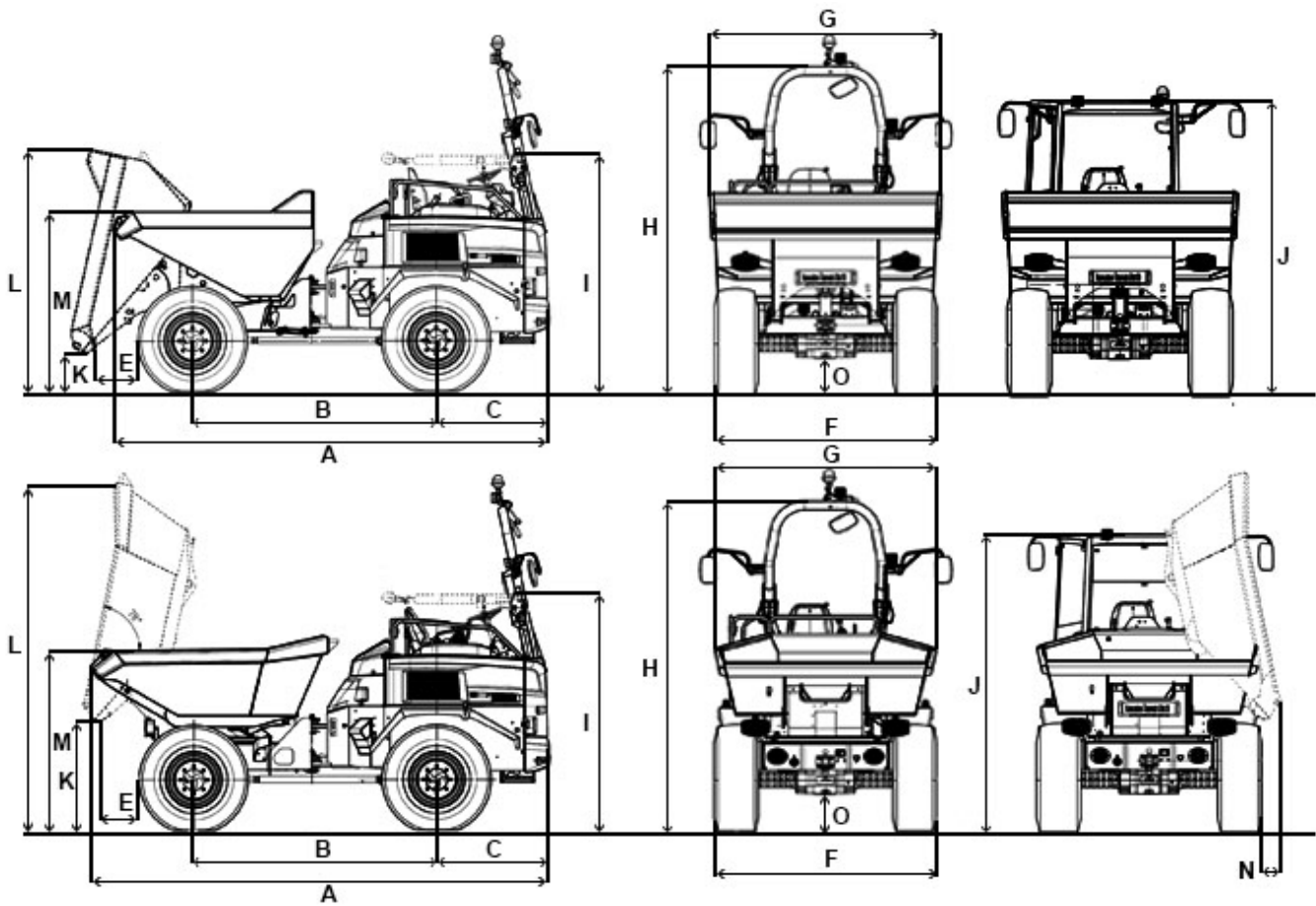

		Front tip skip	Swivel tip skip
A	Overall length ROPS	4,448 mm	4,688 mm
A	Overall length Cabin	4,548 mm	4,799 mm
B	Wheelbase	2,485 mm	2,485 mm
C	Rear overhang	1,157 mm	1,157 mm
E	Dumping distance	565 mm	456 mm
F	Width	2,230 mm	2,230 mm
G	Skip width	2,328 mm	2,217 mm
H	Height ROPS	3,302 mm	3,302 mm
I	Height ROPS tilted	2,395 mm	2,395 mm



J	Height Cabin	2,939 mm	2,938 mm
K	Dump height max.	385 mm	1,136 mm
L	Skip height tilted	2,463 mm	3,639 mm
M	Skip height	1,828 mm	1,981 mm
O	Ground clearance	370 mm	370 mm
-	Dump angle	50 °	48 °

Please note

that product availability can vary from country to country. It is possible that information / products may not be available in your country. More detailed information on engine power can be found in the operator's manual; the stated power may vary due to specific operating conditions.

Subject to alterations and errors excepted. Applicable also to illustrations.

Copyright © 2018 Wacker Neuson SE.